



SPECIFICATION FOR LCD MODULE

Customer : _____

CustomerP/N _____

Model No. : ESHX067B-0100

Version : 1.0

Date : 2018-01-26

Final Approval by Customer

LCM Machinery OK <input type="checkbox"/>	Checked By	
LCM Display OK <input type="checkbox"/>	Checked By	
LCM NG <input type="checkbox"/> LCM OK <input type="checkbox"/>	Approved By	

Confirmed :

DESIGN	CHECK	APPROVAL

Contents

1. Block Diagram	5
2. Outline dimension	6
3. Input terminal Pin Assignment	7
4. LCD Optical Characteristics	9
4.1 Optical specification	9
5. Electrical Characteristics	10
5.1 Absolute Maximum Rating (Ta=25 VSS=0V)	10
5.2 DC Electrical Characteristics	10
5.3 LED Backlight Characteristics	11
6. AC Characteristic	13
TBD	13
7. LCD Module Out-Going Quality Level	14
7.1 VISUAL & FUNCTION INSPECTION STANDARD	14
7.1.1 Inspection conditions	14
7.1.2 Definition	14
7.1.3 Sampling Plan	15
7.1.4 Criteria (Visual)	16
8. Reliability Test Result	21
9. Cautions and Handling Precautions	22
9.1 Handling and Operating the Module	22
9.2 Storage and Transportation	22
10. Packing	23



* Description

This is a color active matrix TFT (Thin Film Transistor) LCD (liquid crystal display) that uses amorphous silicon TFT as a switching device. This model is composed of a Transmissive type TFT-LCD Panel, driver circuit, back-light unit. The resolution of a 6.7'TFT-LCD contains 1920X1080 pixels, and can display up to 65K/262K/16.7M colors.

* Features

-Low Input Voltage: 3.3V (TYP)

-Display Colors of TFT LCD: 65K/262K/16.7M colors

Interface: 6/8BIT LVDS+EBD

General Information Items	Specification	Unit	Note
	Main Panel		
Display area(AA)	148.32(H) *83.43(V) (6.7inch)	mm	-
Driver element	TFT active matrix	-	-
Display colors	65K/262K/16.7M	colors	-
Number of pixels	1920(RGB)*1080	dots	-
TFT Pixel arrangement	RGB vertical stripe	-	-
Pixel pitch	0.07725(H) x 0.07725 (V)	mm	-
Viewing angle	ALL	o'clock	-
Display mode	Transmissive/Normally Black	-	-
Operating temperature	-20~+70	°C	-
Storage temperature	-30~+80	°C	-

* Mechanical Information

Item		Min.	Typ.	Max.	Unit	Note
Module size	Horizontal(H)		161.12		mm	-
	Vertical(V)		97.68		mm	-
	Depth(D)		4.77		mm	-
Weight			124		g	-

1. Block Diagram

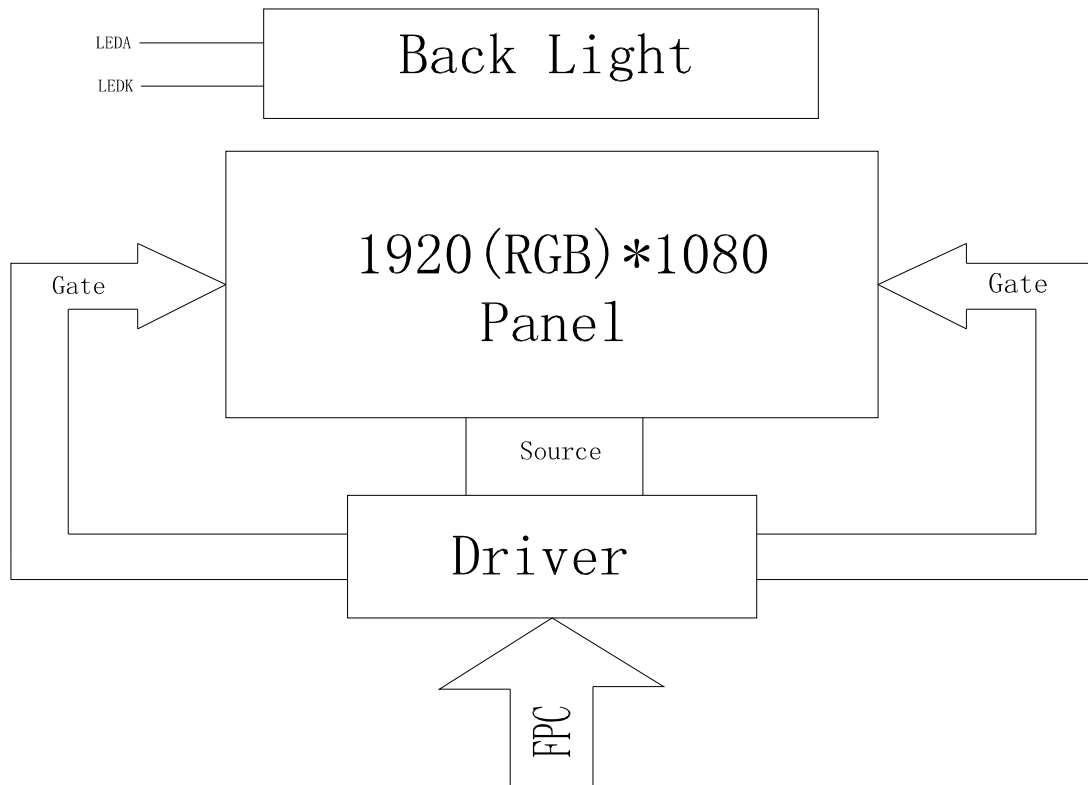

2. Outline dimension

Note: The LCD V.A is the Recommended opening of Lens.

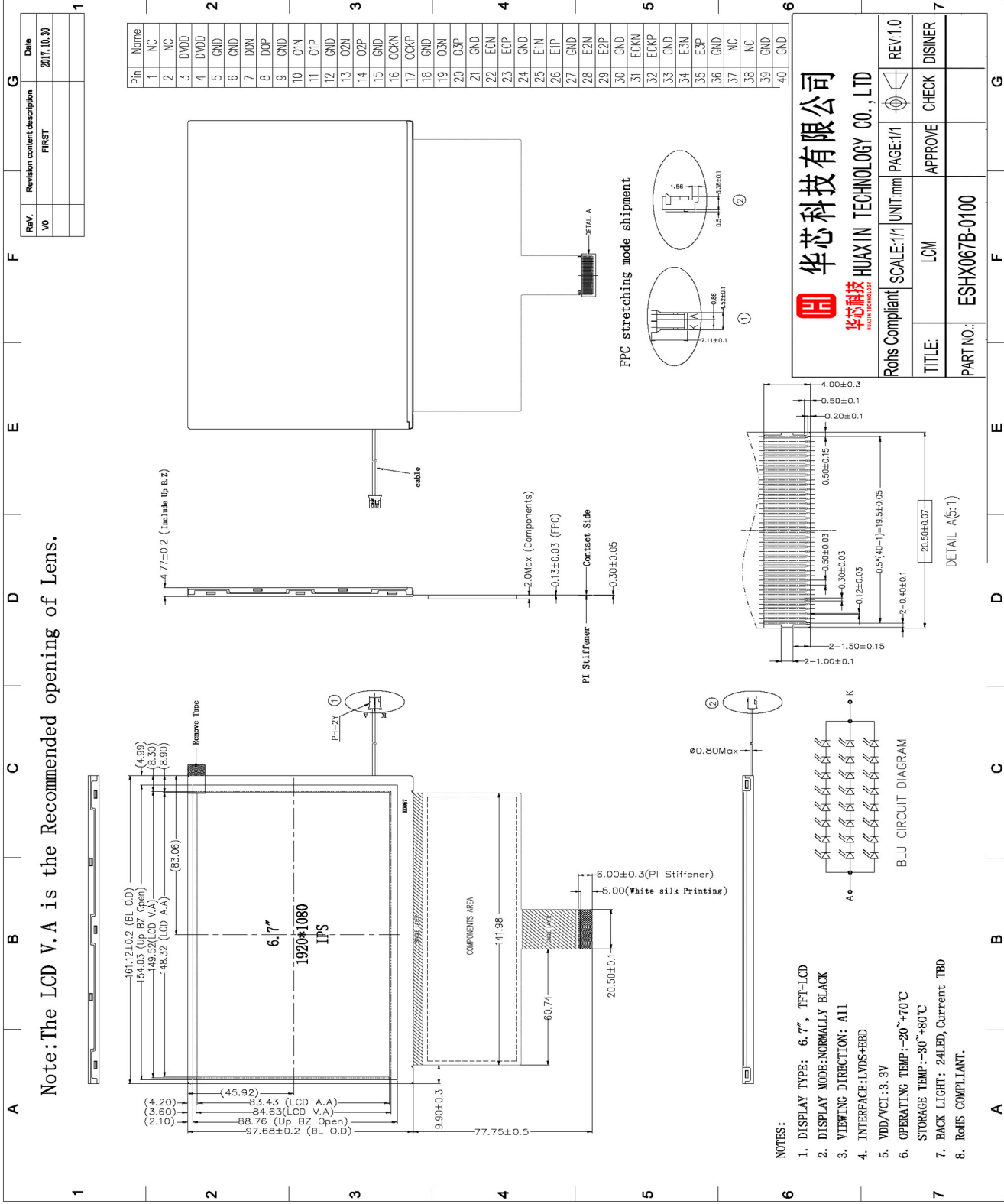

华芯科技
HUAXIN TECHNOLOGY CO., LTD

Rohs Compliant	SCALE:1/1	UNIT:mm	PAGE:1/1	REV:1.0
TITLE:	LCM	APPROVE	CHECK	DISINER
PART NO.:	ESHX067B-0100			

- NOTES:
1. DISPLAY TYPE: 6.7", TFT-LCD
 2. DISPLAY MODE: NORMALLY BLACK
 3. VIEWING DIRECTION: ALL
 4. INTERFACE: LVDS+HBB
 5. VDD/VCI: 3.3V
 6. OPERATING TEMP: -20°~70°C
STORAGE TEMP: -30°~80°C
 7. BACK LIGHT: 24LED, Current TBD
 8. RoHS COMPLIANT.

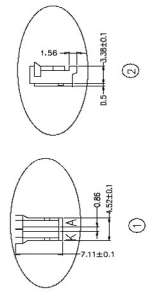
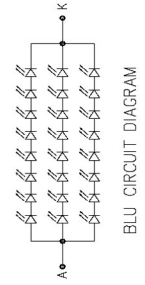

DETAIL A(5:1)

3. Input terminal Pin Assignment

NO.	SYMBOL	DISCRIPTION	I/O
1	NC	-	-
2	NC	-	-
3	DVDD	Supply voltage (3.3V).	P
4	DVDD	Supply voltage (3.3V).	P
5	GND	Ground.	P
6	GND	Ground.	P
7	D0N	- LVDS differential data input	I
8	D0P	+ LVDS differential data input	I
9	GND	Ground.	P
10	D1N	- LVDS differential data input	I
11	D1P	+ LVDS differential data input	I
12	GND	Ground.	P
13	D2N	- LVDS differential data input	I
14	D2P	+ LVDS differential data input	I
15	GND	Ground.	P
16	OCKN	- LVDS differential clock input	I
17	OCKP	+ LVDS differential clock input	I
18	GND	Ground.	P
19	D3N	LVDS differential data input	I
20	D3P	+ LVDS differential data input	I
21	GND	Ground.	P
22	E0N	- LVDS1 differential data input	I
23	E0P	+ LVDS1 differential data input	I
24	GND	Ground.	P
25	E1N	- LVDS1 differential data input	I



华芯科技有限公司

HUAXIN TECHNOLOGY CO., LTD

26	E1P	+ LVDS1 differential data input	I
27	GND	Ground.	P
28	E2N	- LVDS1 differential data input	I
29	E2P	+ LVDS1 differential data input	I
30	GND	Ground.	P
31	ECKN	- LVDS1 differential clock input	I
32	ECKP	+ LVDS1 differential clock input	I
33	GND	Ground.	P
34	E3N	- LVDS1 differential data input	I
35	E3P	+ LVDS1 differential data input	I
36	GND	Ground.	P
37	NC	-	-
38	NC	-	-
39	GND	Ground.	P
40	GND	Ground.	P

4. LCD Optical Characteristics

4.1 Optical specification

Item	Symbol	Condition	Min.	Typ.	Max.	Unit.	Note
Contrast Ratio	CR	$\Theta=0$	--	TBD	--		2
Response time	Rising	Normal viewing angle	--	--	--	msec	3
	Falling						
Color gamut	S(%)		--	TBD	--	%	
Color Filter Chromaticity	White	W_X	0.2764	0.3164	0.3564		
		W_Y	0.3120	0.3520	0.3920		
	Red	R_X	0.5509	0.5909	0.6309		
		R_Y	0.2885	0.3285	0.3685		
	Green	G_X	0.2920	0.3320	0.3720		
		G_Y	0.4914	0.5314	0.5714		
	Blue	B_X	0.1185	0.1585	0.1985		
		B_Y	0.1172	0.1572	0.1972		
Viewing angle	Hor.	Θ_L	--	80	--		
		Θ_R	--	80	--		
	Ver.	Θ_U	--	80	--		
		Θ_D	--	80	--		
Option View Direction	ALL						

5. Electrical Characteristics

5.1 Absolute Maximum Rating (Ta=25 VSS=0V)

Characteristics	Symbol	Min.	Max.	Unit
Digital Supply Voltage	DVDD	-0.3	4.0	V
Operating temperature	T _{OP}	-20	+70	°C
Storage temperature	T _{ST}	-30	+80	°C

NOTE: If the absolute maximum rating of even is one of the above parameters is exceeded even momentarily, the quality of the product may be degraded. Absolute maximum ratings, therefore, specify the values exceeding which the product may be physically damaged. Be sure to use the product within the range of the absolute maximum ratings.

5.2 DC Electrical Characteristics

Characteristics	Symbol	Min.	Typ.	Max.	Unit	Note
Digital Supply Voltage	DVDD	3.0	3.3	3.6	V	
Digital Supply current	IDD	--	TBD	--	mA	
Level input voltage	V _{IH}	0.7V _{DD}	-	V _{DD}	V	
	V _{IL}	GND	-	0.3V _{DD}	V	
Level output voltage	V _{OH}	0.8V _{DD}	-	V _{DD}	V	
	V _{OL}	GND	-	0.2V _{DD}	V	

5.3 LED Backlight Characteristics

The back-light system is edge-lighting type with 24 chips White LED

Item	Symbol	Min.	Typ.	Max.	Unit	Note
Forward Current	I_F	--	120	180	mA	
Forward Voltage	V_F	--	25.6	--	V	
LCM Luminance	L_v	--	800	1000	cd/m ²	Note3
LED life time	Hr	50000	--	--	Hour	Note1,2
Uniformity	AVg	80	--	--	%	Note3

Note (1) LED life time (Hr) can be defined as the time in which it continues to operate under the condition:

$T_a=25\pm 3\text{ }^\circ\text{C}$, typical IL value indicated in the above table until the brightness becomes less than 50%.

Note (2) The "LED life time" is defined as the module brightness decrease to 50% original brightness at $T_a=25\text{ }^\circ\text{C}$ and $I_L=180\text{mA}$. The LED lifetime could be decreased if operating I_L is larger than 180mA. The constant current driving method is suggested.

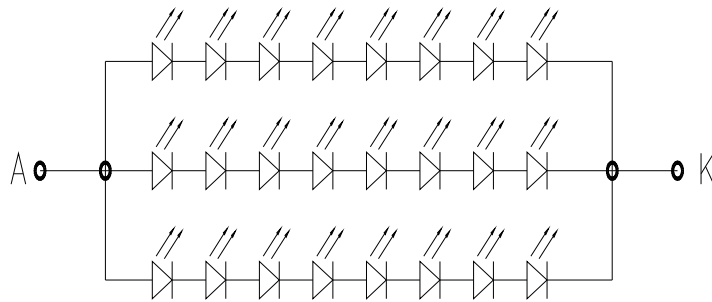

BLU CIRCUIT DIAGRAM

NOTE 3: Luminance Uniformity of these 9 points is defined as below:

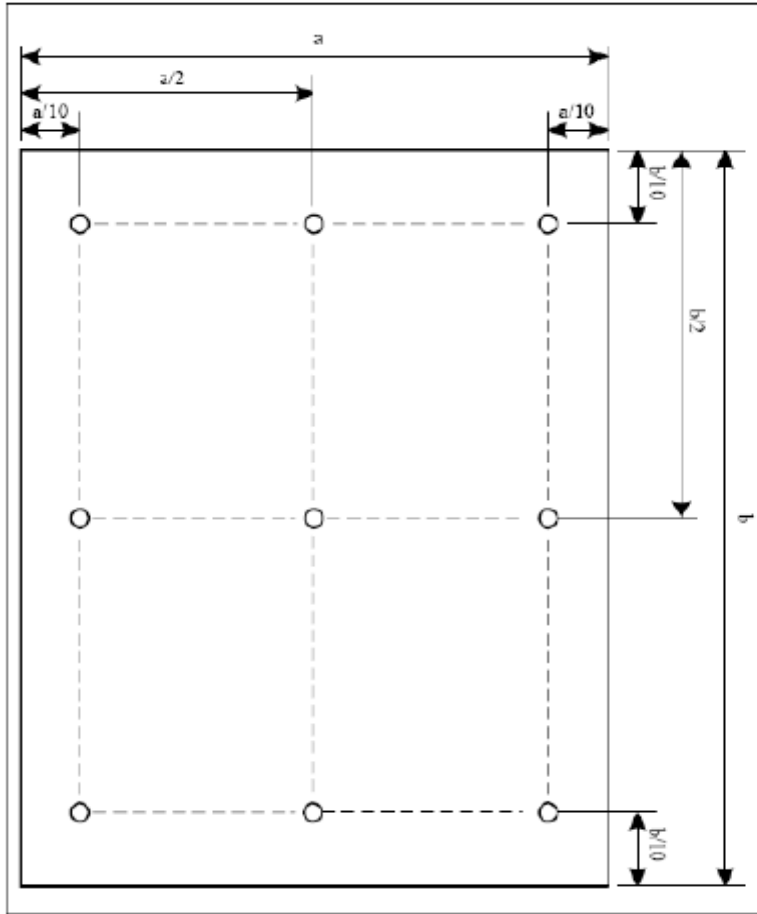

$$\text{Uniformity} = \frac{\text{minimum luminance in 9 points (1-9)}}{\text{maximum luminance in 9 points (1-9)}}$$

$$\text{Luminance} = \frac{\text{Total Luminance of 9 points}}{9}$$

6. AC Characteristic

TBD

7. LCD Module Out-Going Quality Level

7.1 VISUAL & FUNCTION INSPECTION STANDARD

7.1.1 Inspection conditions

Inspection performed under the following conditions is recommended.

Temperature : $25\pm 5^{\circ}\text{C}$

Humidity : $65\%\pm 10\%\text{RH}$

Viewing Angle : Normal viewing Angle.

Illumination: Single fluorescent lamp (300 to 700Lux)

Viewing distance:30-50cm

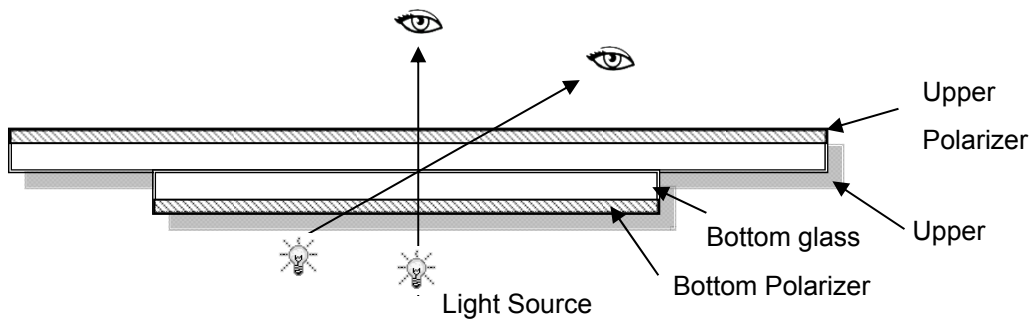

7.1.2 Definition

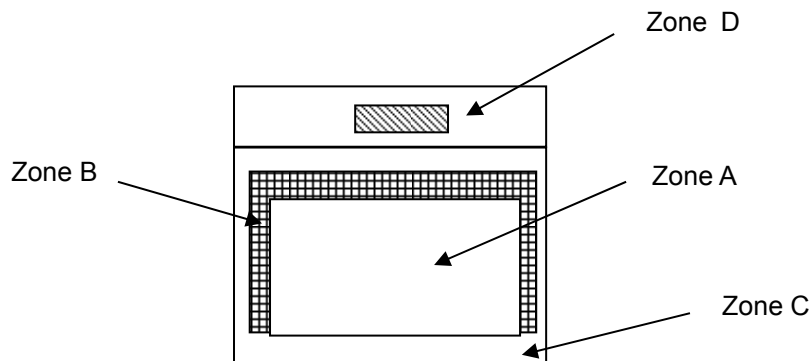

Zone A : Effective Viewing Area(Character or Digit can be seen)

Zone B : Viewing Area except Zone A

Zone C : Outside (Zone A+Zone B) which can not be seen after assembly by customer .)

Zone D : IC Bonding Area

Note:As a general rule ,visual defects in Zone C can be ignored when it doesn't effect product function or appearance after assembly by customer

7.1.3 Sampling Plan

According to GB/T 2828-2003 ; , normal inspection, Class II

AQL:

Major defect	Minor defect
0.65	1.5

LCD: Liquid Crystal Display , TP: Touch Panel , LCM: Liquid Crystal Module

No	Items to be inspected	Criteria	Classification of defects
1	Functional defects	1) No display, Open or miss line 2) Display abnormally, Short 3) Backlight no lighting, abnormal lighting. 4) TP no function	Major
2	Missing	Missing component	
3	Outline dimension	Overall outline dimension beyond the drawing is not allowed	
4	Color tone	Color unevenness, refer to limited sample	Minor
5	Spot Line defect	Light dot, Dim spot, Polarizer Bubble ; Polarizer accidented spot.	
6	Soldering appearance	Good soldering , Peeling off is not allowed.	
7	LCD/Polarizer/TP	Black/White spot/line, scratch, crack, etc.	

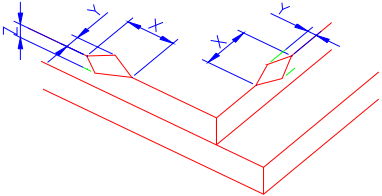
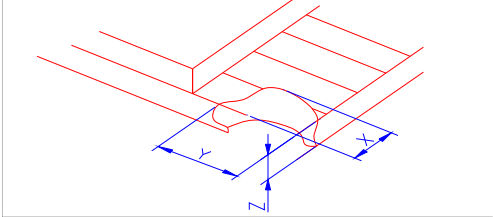
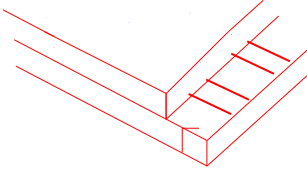

7.1.4 Criteria (Visual)

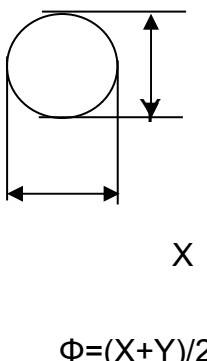
Number	Items	Criteria(mm)						
1.0 LCD Crack/Broken NOTE: X: Length Y: Width Z: Height L: Length of ITO, T: Height of LCD	(1) The edge of LCD broken	 <table border="1" data-bbox="756 667 1455 815"> <thead> <tr> <th>X</th> <th>Y</th> <th>Z</th> </tr> </thead> <tbody> <tr> <td>≤3.0mm</td> <td><Inner border line of the seal</td> <td>≤T</td> </tr> </tbody> </table>	X	Y	Z	≤3.0mm	<Inner border line of the seal	≤T
X	Y	Z						
≤3.0mm	<Inner border line of the seal	≤T						
	(2)LCD corner broken	 <table border="1" data-bbox="836 1122 1375 1223"> <thead> <tr> <th>X</th> <th>Y</th> <th>Z</th> </tr> </thead> <tbody> <tr> <td>≤3.0mm</td> <td>≤L</td> <td>≤T</td> </tr> </tbody> </table>	X	Y	Z	≤3.0mm	≤L	≤T
X	Y	Z						
≤3.0mm	≤L	≤T						
	(3) LCD crack	 <p style="text-align: center;">Crack Not allowed</p>						

2.0	Spot defect	 <p style="text-align: center;">$\Phi=(X+Y)/2$</p>	① light dot (LCD/TP/Polarizer black/white spot , light dot, pinhole, dent, stain)				
	Zone		Acceptable Qty				
	Size (mm)		A	B	C	Ignore	
	$\Phi \leq 0.10$		Ignore				
	$0.10 < \Phi \leq 0.25$		4(distance $\geq 10\text{mm}$)				
$0.25 < \Phi \leq 0.35$		3					
$\Phi > 0.4$		0					
② Dim spot (LCD/TP/Polarizer dim dot, light leakage, dark spot)							
Zone		Acceptable Qty			Ignore		
Size (mm)		A	B	C			
$\Phi \leq 0.1$		Ignore					
$0.10 < \Phi \leq 0.25$		4(distance $\geq 10\text{mm}$)					
$0.25 < \Phi \leq 0.35$		3					
$\Phi > 0.4$		0					
③ Polarizer accidented spot							
Zone		Acceptable Qty			Ignore		
Size (mm)		A	B	C			
$\Phi \leq 0.2$		Ignore					
$0.3 < \Phi \leq 0.5$		3(distance $\geq 10\text{mm}$)					
$\Phi > 0.5$		1					
④ Pixel bad points (light dot, Dim dot, color dot)							
Zone		Acceptable Qty			Ignore		
Size (mm)		A	B	C			
$\Phi \leq 0.15$		Ignore					
$0.2 < \Phi \leq 0.3$		2(distance $\geq 10\text{mm}$)					
$\Phi > 0.4$		1					
⑤ Polarizer Bubble							
Zone		Acceptable Qty			Ignore		
Size (mm)		A	B	C			
$\Phi \leq 0.2$		Ignore					
$0.3 < \Phi \leq 0.4$		4(distance $\geq 10\text{mm}$)					
$0.4 < \Phi \leq 0.5$		3					
$\Phi > 0.5$		1					

3.0	Line defect (LCD/TP /Polarizer backlight black/white line, scratch, stain)	<table border="1"> <thead> <tr> <th rowspan="2">Width(mm)</th> <th rowspan="2">Length(m m)</th> <th colspan="3">Acceptable Qty</th> </tr> <tr> <th>A</th> <th>B</th> <th>C</th> </tr> </thead> <tbody> <tr> <td>$\Phi \leq 0.05$</td> <td>Ignore</td> <td colspan="2">Ignore</td> <td rowspan="3">Ignore</td> </tr> <tr> <td>$0.05 < W \leq 0.06$</td> <td>$L \leq 5.0$</td> <td colspan="2">$N \leq 3$</td> </tr> <tr> <td>$0.07 < W \leq 0.08$</td> <td>$L \leq 4.0$</td> <td colspan="2">$N \leq 2$</td> </tr> <tr> <td>$0.08 < W$</td> <td colspan="4">Define as spot defect</td> </tr> </tbody> </table>	Width(mm)	Length(m m)	Acceptable Qty			A	B	C	$\Phi \leq 0.05$	Ignore	Ignore		Ignore	$0.05 < W \leq 0.06$	$L \leq 5.0$	$N \leq 3$		$0.07 < W \leq 0.08$	$L \leq 4.0$	$N \leq 2$		$0.08 < W$	Define as spot defect			
		Width(mm)			Length(m m)	Acceptable Qty																						
			A	B		C																						
		$\Phi \leq 0.05$	Ignore	Ignore		Ignore																						
		$0.05 < W \leq 0.06$	$L \leq 5.0$	$N \leq 3$																								
$0.07 < W \leq 0.08$	$L \leq 4.0$	$N \leq 2$																										
$0.08 < W$	Define as spot defect																											
4.0	Electronic Comp onents SMT	Not allow missing parts, solderless connection, cold solder joint, mis match, The positive and negative polarity opposite																										
5.0	Display color& B rightness	<ol style="list-style-type: none"> Color: Measuring the color coordinates, The measurement standar d according to the datasheet or samples. Brightness: Measuring the brightness of White screen, The measu rement standard according to the datasheet or Samples. 																										
6.0	LCD Mura	By 5% ND filter invisible.																										

7.0	RTP Related	TP film bubble/ accidented spot	<table border="1"> <thead> <tr> <th rowspan="2">Size Φ(mm)</th> <th colspan="3">Acceptable Qty</th> </tr> <tr> <th>A</th> <th>B</th> <th>C</th> </tr> </thead> <tbody> <tr> <td>$\Phi \leq 0.1$</td> <td colspan="3">Ignore</td> </tr> <tr> <td>$0.1 < \Phi \leq 0.25$</td> <td colspan="3">4 (distance ≥ 10mm)</td> </tr> <tr> <td>$0.25 < \Phi \leq 0.35$</td> <td colspan="3">3</td> </tr> <tr> <td>$\Phi > 0.4$</td> <td colspan="3">1</td> </tr> </tbody> </table>	Size Φ (mm)	Acceptable Qty			A	B	C	$\Phi \leq 0.1$	Ignore			$0.1 < \Phi \leq 0.25$	4 (distance ≥ 10 mm)			$0.25 < \Phi \leq 0.35$	3			$\Phi > 0.4$	1					
		Size Φ (mm)	Acceptable Qty																										
A	B		C																										
$\Phi \leq 0.1$	Ignore																												
$0.1 < \Phi \leq 0.25$	4 (distance ≥ 10 mm)																												
$0.25 < \Phi \leq 0.35$	3																												
$\Phi > 0.4$	1																												
		TP film scratch	<table border="1"> <thead> <tr> <th rowspan="2">Width(mm)</th> <th rowspan="2">Length(mm)</th> <th colspan="3">Acceptable Qty</th> </tr> <tr> <th>A</th> <th>B</th> <th>C</th> </tr> </thead> <tbody> <tr> <td>$\Phi \leq 0.05$</td> <td>Ignore</td> <td colspan="2">Ignore</td> <td rowspan="3">Ignore</td> </tr> <tr> <td>$0.05 < W \leq 0.06$</td> <td>$L \leq 5.0$</td> <td colspan="2">$N \leq 3$</td> </tr> <tr> <td>$0.07 < W \leq 0.08$</td> <td>$L \leq 4.0$</td> <td colspan="2">$N \leq 2$</td> </tr> <tr> <td>$0.08 < W$</td> <td colspan="4">Define as spot defect</td> </tr> </tbody> </table>	Width(mm)	Length(mm)	Acceptable Qty			A	B	C	$\Phi \leq 0.05$	Ignore	Ignore		Ignore	$0.05 < W \leq 0.06$	$L \leq 5.0$	$N \leq 3$		$0.07 < W \leq 0.08$	$L \leq 4.0$	$N \leq 2$		$0.08 < W$	Define as spot defect			
Width(mm)	Length(mm)	Acceptable Qty																											
		A	B	C																									
$\Phi \leq 0.05$	Ignore	Ignore		Ignore																									
$0.05 < W \leq 0.06$	$L \leq 5.0$	$N \leq 3$																											
$0.07 < W \leq 0.08$	$L \leq 4.0$	$N \leq 2$																											
$0.08 < W$	Define as spot defect																												

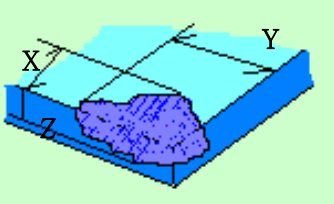
Assembly deflection	beyond the edge of backlight $\leq 0.2\text{mm}$								
Bulge (undulation included)	<p>The ITO film plumped below 0.40mm, it's ok.</p> 								
Newton Ring	<p>Newton Ring area $> 1/3$ TP area NG</p> <p>Newton Ring area $\leq 1/3$ TP area OK</p>								
TP corner broken X : length Y : width Z : height	<table border="1" data-bbox="710 1489 1141 1668"> <thead> <tr> <th>X</th> <th>Y</th> <th>Z</th> </tr> </thead> <tbody> <tr> <td>$X \leq 3\text{mm}$</td> <td>$Y \leq 3\text{mm}$</td> <td>$Z < \text{COVER thickness}$ s</td> </tr> </tbody> </table> <p>*Circuitry broken is not allowed.</p>		X	Y	Z	$X \leq 3\text{mm}$	$Y \leq 3\text{mm}$	$Z < \text{COVER thickness}$ s	
X	Y	Z							
$X \leq 3\text{mm}$	$Y \leq 3\text{mm}$	$Z < \text{COVER thickness}$ s							

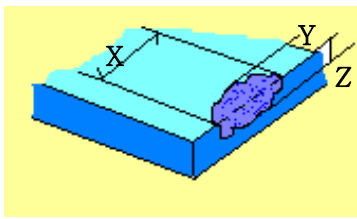
			X	Y	Z	
		TP edge broken	X≤4mm	Y≤2mm	Z<COVER thickness	
		X : length Y : width Z : height	* Circuitry broken is not allowed.			

Criteria (functional items)

Number	Items	Criteria (mm)
1	No display	Not allowed
2	Missing segment	Not allowed
3	Short	Not allowed
4	Backlight no lighting	Not allowed
5	TP no function	Not allowed

8. Reliability Test Result

Item	Condition	Inspection after test
High Temperature Operating	70℃,96H	Inspection after 2~4hours storage at room temperature, the sample shall be free from defects: 1.Air bubble in the LCD; 2.Non-display; 3.Missing segments/line; 4.Glass crack; 5.Current IDD is twice higher than initial value.
Low Temperature Operating	-20℃, 96HR	
High Temperature Storage	80℃, 96HR	
Low Temperature Storage	-30℃, 96HR	
High Temperature & High Humidity Storage	+60℃, 90% RH ,96 hours.	
Thermal Shock (Non-operation)	-20℃,30 min ↔ 70℃,30 min, Change time:5min 20CYC.	
ESD test	C=150pF, R=330,5points/panel Air:±8KV, 5times; Contact:±6KV, 5 times; (Environment: 15℃~35℃, 30%~60%).	
Vibration (Non-operation)	Frequency range:10~55Hz, Stroke:1.5mm Sweep:10Hz~55Hz~10Hz 2 hours for each direction of X.Y.Z. (6 hours for total) (Package condition).	
Box Drop Test	1 Corner 3 Edges 6 faces,80cm(MEDIUM BOX)	

Remark:

- 1.The test samples should be applied to only one test item.
- 2.Sample size for each test item is 5~10pcs.
- 3.For Damp Proof Test, Pure water(Resistance > 10MΩ) should be used.
- 4.In case of malfunction defect caused by ESD damage, if it would be recovered to normal state after resetting, it would be judged as a good part.
- 5.Failure Judgment Criterion: Basic Specification, Electrical Characteristic, Mechanical Characteristic, Optical Characteristic.

9. Cautions and Handling Precautions

9.1 Handling and Operating the Module

- (1) When the module is assembled, it should be attached to the system firmly.
Do not warp or twist the module during assembly work.
- (2) Protect the module from physical shock or any force. In addition to damage, this may cause improper operation or damage to the module and back-light unit.
- (3) Note that polarizer is very fragile and could be easily damaged. Do not press or scratch the surface.
- (4) Do not allow drops of water or chemicals to remain on the display surface.
If you have the droplets for a long time, staining and discoloration may occur.
- (5) If the surface of the polarizer is dirty, clean it using some absorbent cotton or soft cloth.
- (6) The desirable cleaners are water, IPA (Isopropyl Alcohol) or Hexane.
Do not use ketene type materials (ex. Acetone), Ethyl alcohol, Toluene, Ethyl acid or Methyl chloride. It might permanent damage to the polarizer due to chemical reaction.
- (7) If the liquid crystal material leaks from the panel, it should be kept away from the eyes or mouth. In case of contact with hands, legs, or clothes, it must be washed away thoroughly with soap.
- (8) Protect the module from static; it may cause damage to the CMOS ICs.
- (9) Use finger-stalls with soft gloves in order to keep display clean during the incoming inspection and assembly process.
- (10) Do not disassemble the module.
- (11) Protection film for polarizer on the module shall be slowly peeled off just before use so that the electrostatic charge can be minimized.
- (12) Pins of I/F connector shall not be touched directly with bare hands.
- (13) Do not connect, disconnect the module in the "Power ON" condition.
- (14) Power supply should always be turned on/off by the item 6.1 Power On Sequence & 6.2 Power Off Sequence

9.2 Storage and Transportation.

- (1) Do not leave the panel in high temperature, and high humidity for a long time.
It is highly recommended to store the module with temperature from 0 to 35 °C and relative humidity of less than 70%
- (2) Do not store the TFT-LCD module in direct sunlight.
- (3) The module shall be stored in a dark place. When storing the modules for a long time, be sure to adopt effective measures for protecting the modules from strong ultraviolet radiation, sunlight, or fluorescent light.
- (4) It is recommended that the modules should be stored under a condition where no condensation is allowed. Formation of dewdrops may cause an abnormal operation or a failure of the module.
In particular, the greatest possible care should be taken to prevent any module from being operated where condensation has occurred inside.
- (5) This panel has its circuitry FPC on the bottom side and should be handled carefully in order not to be stressed.

10. Packing

---TBD-----